

ER-S2U

universal 2 space rack shelf

Product Features:

fits components up to 17.375" wide

racking height - 2 space (3 1/2")

tray depth - 14.75"

load capacity - 50 lbs.

static resistant black powder coat finish

includes 10-32 and 12-24 mounting screws

Product Specifications:

(for Architects & Engineers)

The equipment rack shelf shall be the Video Mount Products (VMP) model ER-S2U. The shelf shall be compatible with standard 19" equipment racks without modification. The shelf shall fit all components up to 17.375" in width. The shelf shall be painted with a durable black static resistant powder coat finish. The load capacity shall be 50 lbs.

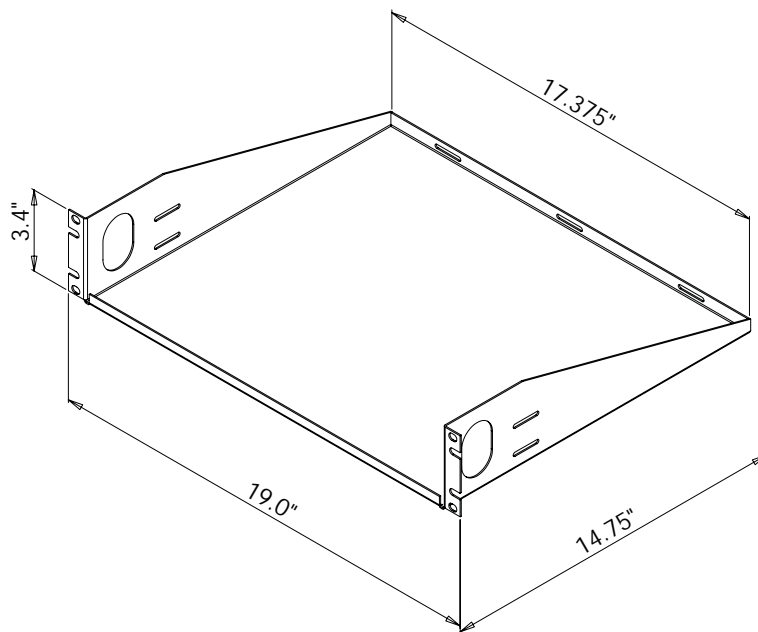

Video Mount Products

325 Log Canoe Circle

Stevensville, MD 21666

Phone: 410.643.6390

Fax: 410.643.6615

www.videomount.com

