

WMP

VIDEO MOUNT PRODUCTS

Instruction Sheet For:

FP-LF

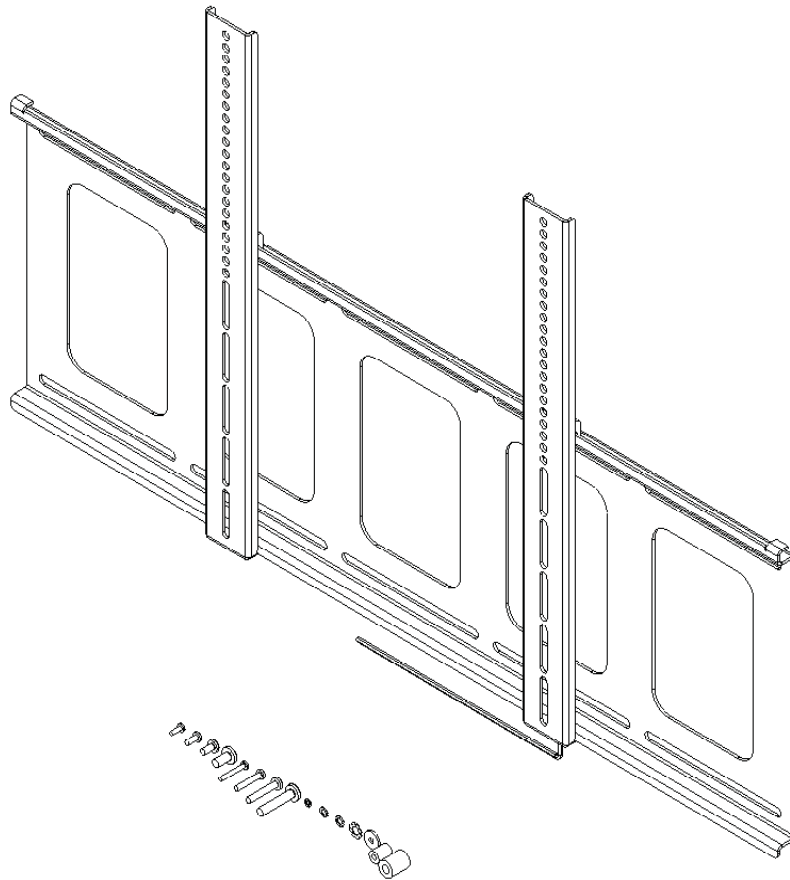

*For more information, please contact us at:
325 Log Canoe Circle, Stevensville, Maryland 21666
(T) 410.643.6390 / (F) 410.643.6615
www.videomount.com*

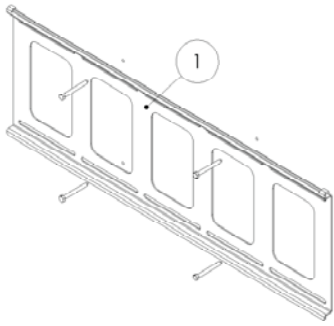

Step 2: Mounting the wall plate
(Lag screws are not included)

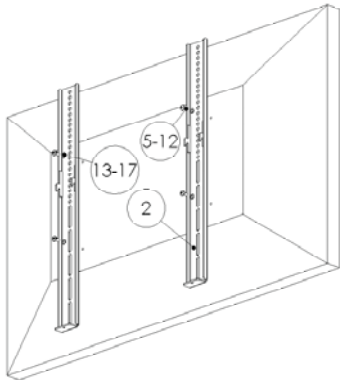

Step 3A: Attaching the mounting
brackets to the monitor
(spacers not needed)

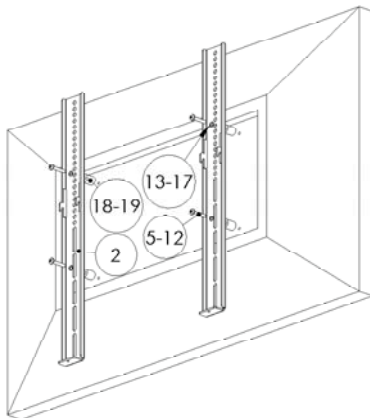

Step 3B: Attaching the mounting
brackets to the monitor (spacers used
due to recessed hole patterns)

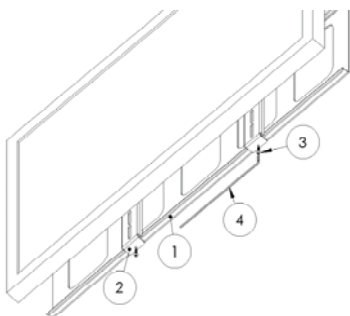

Step 4: Securing the mounting brackets
to the wall plate

Step 1

Before starting, lay out all parts to your mount and match them to the parts list provided. Verify that you have all your parts before attempting to assemble the mount.

Step 2

Mark the wall or desired mounting surface in preparation of installation of the wall plate (1). Pre-drill in necessary and mount the wall plate (1) to the desired mounting surface.

Warning: Please verify that your mounting surface will support the combined weight of your mount, mounting hardware, and monitor. Also verify that the mounting surface is safe to drill through. If in doubt, please contact a profession installer.

Step 3

Determine the correct screw size and if you need to use washers, lock washers, or spacers. **Note: Spacers are used for TVs with recessed hole patterns.** Secure the TV to the mounting bracket (2) using the appropriate hardware (5 through 19). **Note: The brackets have to be level with each other to work properly.**

Step 4

Use the hooks in the mounting bracket (2) to hook on the top rail of the wall plate (1). Use security screws (3) and the long allen key (4) to secure the TVs to the wall plate (1) and to secure its horizontal position.

Please verify that all nuts and screws are securely tightened.

Enjoy Your Mount!

WARNING: The installer of these products must verify that the mounting surface, ceiling or wall, will safely support the combined weight of all attached equipment and hardware. Video Mount products will not be held liable for the improper use or installation of its products.