

**WARNING! SEVERE PERSONAL INJURY AND PROPERTY DAMAGE CAN RESULT FROM IMPROPER INSTALLATION OR ASSEMBLY. READ THE FOLLOWING WARNINGS BEFORE BEGINNING.**

If you do not understand the instructions or have any concerns or questions, please contact a qualified installer

Do not install or assemble if the product or hardware is damaged or missing. If you require replacement parts, contact your distributor for assistance.

For ceiling mounted products: This product has been designed for use in a ceiling mounted configuration, defined by wood beams and joists 2 x 4 inches and greater. If you don't know your ceiling type, or for assistance with other surfaces (steel beams or concrete), contact a qualified installer. For safe installation, the ceiling you are mounting to must support 4 times the weight of the total load. If not, the surface must be reinforced to meet this standard. The installer is responsible for verifying that the ceiling structure/surface and the anchors used in the installation will safely support the total load. For Ceiling mounted products, professional installation is highly recommended.

Do not use this product for any application other than those specified by the instructions.

This product may contain moving parts. Use with caution.

**DO NOT EXCEED THE MAXIMUM WEIGHT CAPACITY FOR THIS PRODUCT.**

1) Find stud(s) and mark edge and center locations.



2) Use ceiling plate to mark mounting location.



3) Mount ceiling plate to ceiling using proper mounting hardware.

4) Insert the ceiling mast into the ceiling plate and secure set screw.



5) Adjust Mast to desired height and insert set bolt.

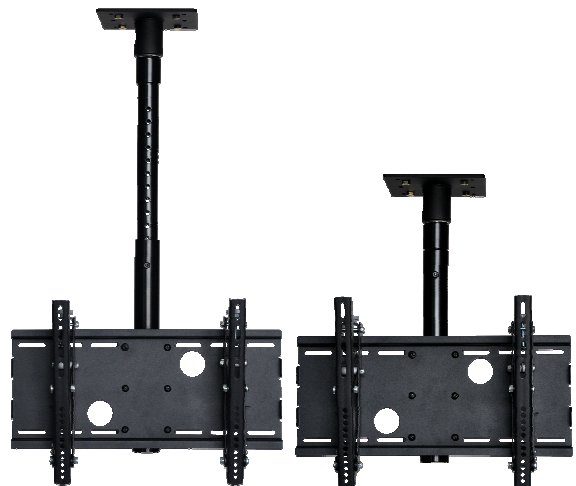

6) Attach Wall Mount Plate to adaptor bracket with supplied (6) screws and nylon lock nuts.

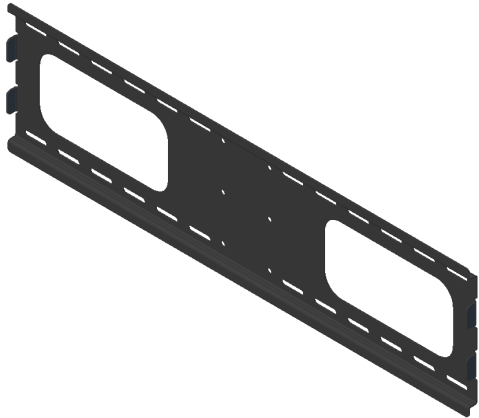

7) Install Adaptor Bracket onto lower end of mast by sliding the mast through large holes in U shaped adaptor bracket.



8) Secure bracket with the supplied threaded collar and tighten set screws.



9) Mount Rails to the back of your Flat Panel

Attach the upright rails to the TV/ Monitor both at equal heights with the tilt control lever to the outside of the TV. Use the supplied hardware to attach the rails to the TV. If your TV/ Monitor has recessed holes or an obstruction on the back that prevents the rail from sitting flush against the TV, install the nylon spacers between the TV/ Monitor and the mounting rail. The screws should not be over tightened nor should the screw bottom out.

10) Lift the TV and Hang onto wall plate.

First hook the TV Rails over the top of the wall plate. Next slide the locking tab up and secure the screws.

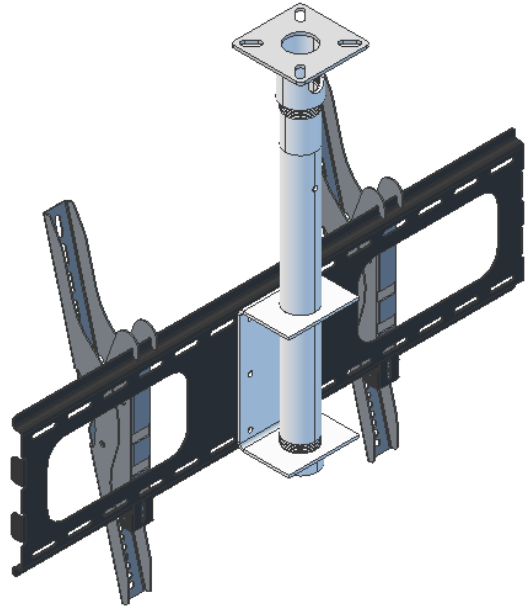

Pictures may not exactly represent the part(s) you are supplied.